



INSTRUCTIONS

-J02896

REV. 2007-07-24

DOCKING HARDWARE KIT

GENERAL

Kit Number

53529-04

Models

For model fitment information, please see the P&A Retail Catalog or the Parts and Accessories section of www.harley-davidson.com (English only).

Tools and Supplies Required

Loctite® 243 (Blue) Threadlocker and Sealant (H-D Part Number 99642-97) is required for the proper installation of this kit.

Kit Contents

See Figure 2 and Table 1.

INSTALLATION

NOTE

Complete the following procedures on one side of the motorcycle before starting the other side.

1. See Figure 1. Remove and discard the front screw (2) and locknut (3) from the rear-fender support cover (1).

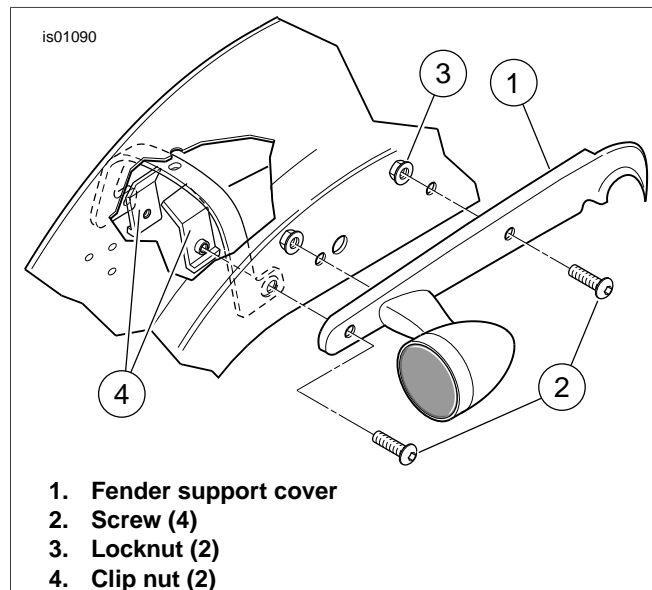

Figure 1. Rear fender Support (Right Side Shown)

2. Remove the rear screw (2) and clip nut (4) from the rear-fender support cover. Discard the screw, but retain the clip nut.

3. See Figure 2. Obtain a front docking point (2), screw (1) and locknut (4) from the kit. Note the small-diameter collar on one end of the docking point.

Place the docking point onto the screw threads with the collar end farthest from the screw head. Coat the screw threads with a few drops of Loctite® 243 (Blue). Insert the screw into the forward rear-fender support hole, fitting the collar on the docking point toward the hole.

Thread a locknut onto the screw threads from underneath the fender. Tighten the locknut to 15 ft-lbs (20 Nm).

4. Obtain a rear docking point (3) and screw (1) from the kit, and the clip nut removed earlier. Note the small-diameter collar on one end of the docking point.

Place the docking point onto the screw threads with the collar end farthest from the screw head. Coat the screw threads with a few drops of Loctite 243 (Blue). Insert the screw into the rearmost rear-fender support hole, fitting the collar on the docking point toward the hole.

Install the clip nut onto the screw threads from underneath the fender. Tighten the screw to 15 ft-lbs (20 Nm).

5. Repeat Steps 1 through 4 for the opposite side of the motorcycle.

MAINTENANCE

NOTE

In time, the docking points may wear causing the mating luggage rack or sideplates to become loose. The fit may be tightened using the following procedure.

1. Loosen the docking hardware.
2. Rotate the docking points clockwise approximately 45°.
3. Tighten the docking hardware to the appropriate torque values as indicated in the installation procedures.

This procedure can be repeated up to three times before replacement of the docking points is recommended.

SERVICE PARTS

is01091

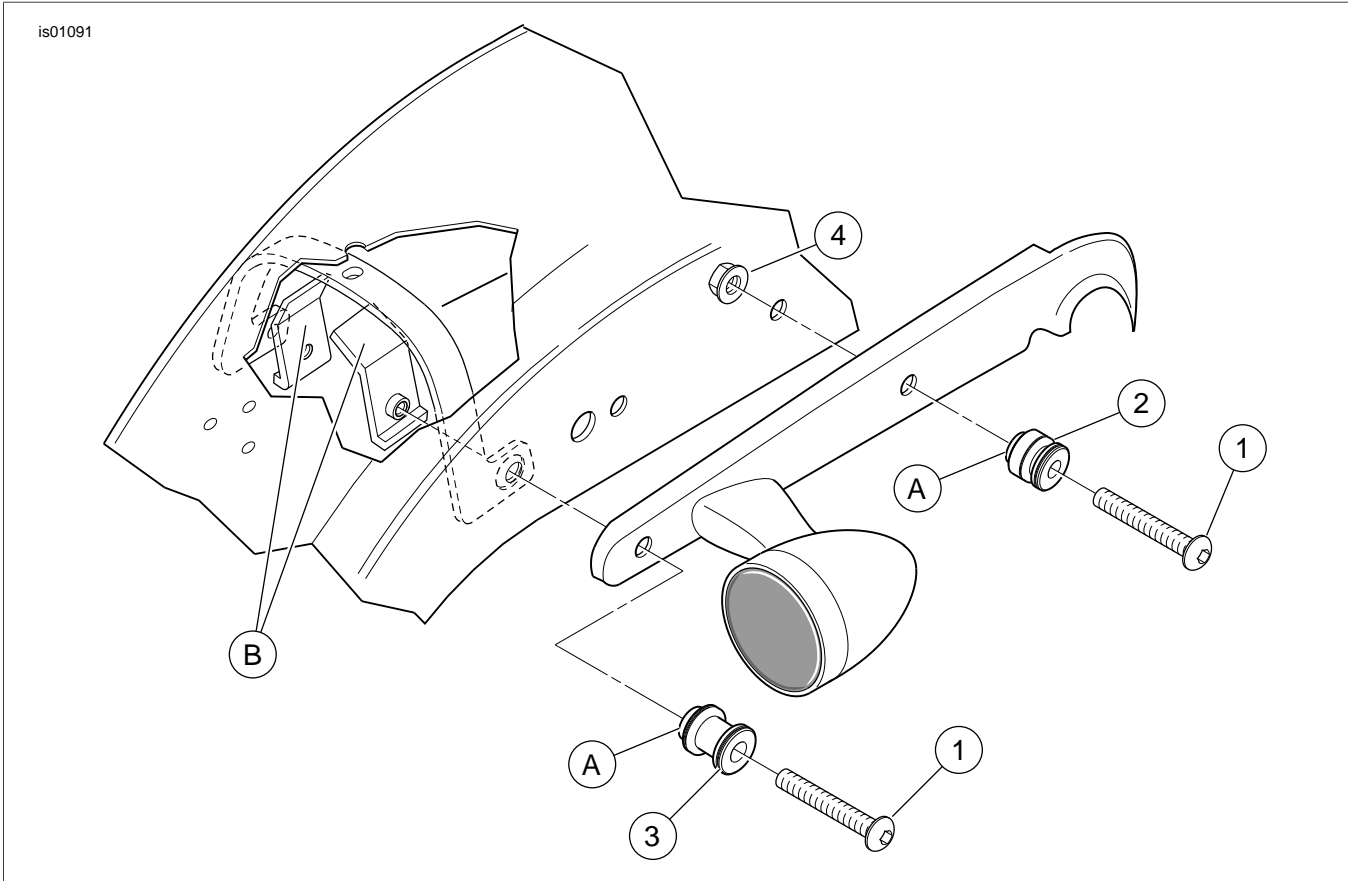

Figure 2. Service Parts: Docking Hardware

Table 1. Service Parts Table

Item	Description (Quantity)	Part Number
1	Screw, hex socket, Chrome, 5/16-18 x 2-1/4 inch (4)	4158
2	Docking point, front (2)	53942-04
3	Docking point, rear (2)	53943-04
4	Locknut, flanged, 5/16-18 (2)	7531
NOTE:		
A	Small diameter mounts toward the fender support cover.	
B	Stock clip nuts shown	