



INSTRUCTIONS

-J02743

REV. 10-26-2004

*Kit Numbers 58860-04 (Chrome), 58882-04BDK (Prime painted) and
58882-XXxxx (Finish painted)*

FRONT SPOILER KIT

General

These kits fit all 2004 and later Sportster® models.

These front spoilers are incompatible with engine guards.

See the Service Parts illustration for kit contents.

NOTE

A Service Manual for your model motorcycle is available from any Harley-Davidson dealer.

Installation

NOTE

The spoiler in kit number 58882-04BDK is finished with a primer coat. Before installation, have the spoiler painted

1. Mount the motorcycle on a lift table.
2. See the Service Parts illustration. Attach the upper front spoiler bracket (4) to the bosses on the inside front of the spoiler (1) with the two Hi-Lo screws (10) from the kit. Tighten to 15-20 **in-lbs** (1.7-2.3 Nm).
3. Attach the lower front spoiler bracket (5) to the two weld nuts in the cross bar at the bottom front of the motorcycle frame with two hex head machine screws (6) and split lockwashers (7) from the kit. Torque to 30 ft-lbs (41 Nm).
4. Remove the protective film from the back of the medallion. Carefully center the medallion on the recessed area on the front of the spoiler.
5. Press the Bar and Shield medallion (3) firmly into position. Hold the medallion in place, pushing hard with your thumbs, for about five seconds. Take care not to shift the medallion on the spoiler.
6. After releasing pressure, avoid direct contact with the medallion for about 20 minutes.
7. Place a flat washer (9) on one of the pan head machine screws (8) from the kit. Position the spoiler to the front of the frame. Insert the screw through the large hole in the bottom of the spoiler and thread it into the upper front spoiler bracket, but do not fully tighten at this time.
8. Place a flat washer on each of the two remaining pan head machine screws from the kit. Insert the screws through the slots in the bottom of the spoiler and thread them into the lower bracket, but do not tighten fully.
9. Position the spoiler next to the vehicle frame allowing an equal amount of minimal clearance. Alternately tighten the three screws to 72 **in-lbs** (8 Nm).



Service Parts

Part No. 58882-XXxxx

Date 10/04

Front Spoiler Kit

105377

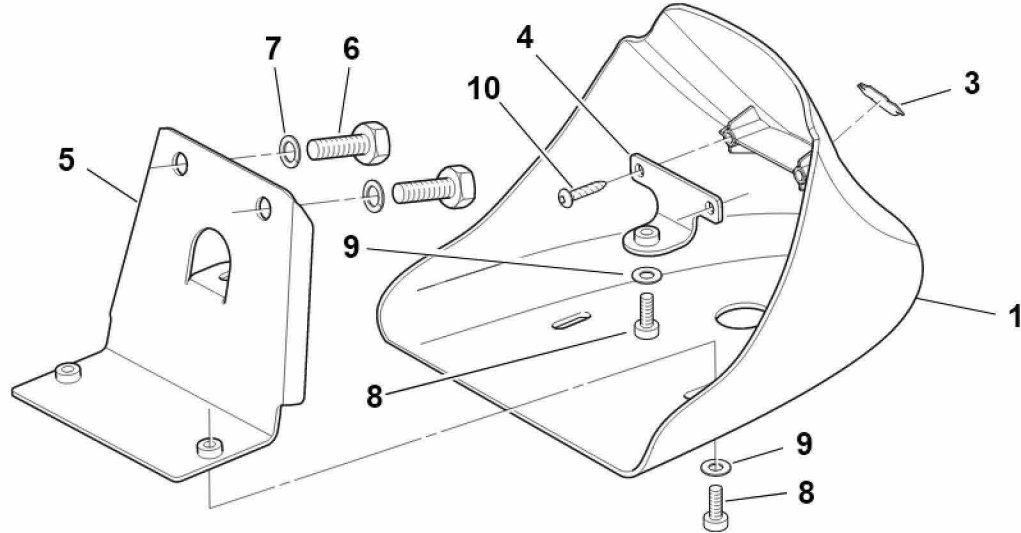

Item	Description (Quantity)	Part No.	Item	Description (Quantity)	Part No.
1	Front spoiler	Not sold separately	6	Machine screw, hex head, 3/8-16 x 3/4 in (2)	4713W
2	Hardware kit (contains items 3 through 10)	58876-04	7	Lockwasher, split, 3/8 in (2)	7038
3	Medallion, Bar and Shield	59354-93	8	Machine screw, hex socket, 1/4-20 x 1/2 in (3)	4365
4	Bracket, upper front spoiler	Not sold separately	9	Flat washer, 1/4 in (3)	6703
5	Bracket, lower front spoiler	Not sold separately	10	Screw, self-tapping, Hi-Lo (2)	3596