

INSTRUCTION MANUAL

STEERING DAMPER KIT

for H-D XL1200/883 SPORTSTER ('88~'03)

Thank you for purchasing DAYTONA STEERING DAMPER KIT.

Product Features

- Stabilizes steering especially at high speed.
- Prevents the front forks from being twisted during high speed cornering.
- Bolt-on mount. The kit includes application specific brackets and all hardware for easy mounting.



1. Read all instructions before use.
2. After installation, check to see if all the parts are correctly installed, and see if all the screws are torqued properly.
3. Do not adjust the damper while riding.
4. Periodical inspection of the installed parts is required every 500km (300mile). If anything unusual may be found while riding, pull over at a safe place to check.

Install

*Install stabilizer on the left side of motorcycle.

Fig.1

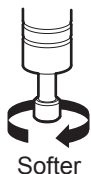

Before installing, turn the adjustable knob counter-clockwise to the end.

Install FRAME BRACKET

1. Remove the front engine mount bolts. Next, put it onto the frame bracket(#3) between the nut plate and the frame, then tighten with supplied two longer bolts(#4).

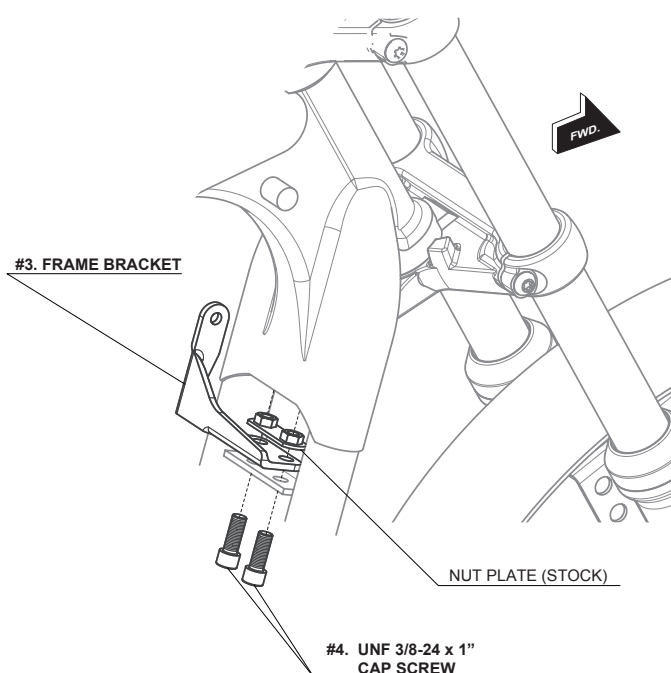

Fig.2

Install FORK BRACKET

2. Attach the front fork bracket set(#2) loosely to the left fork.

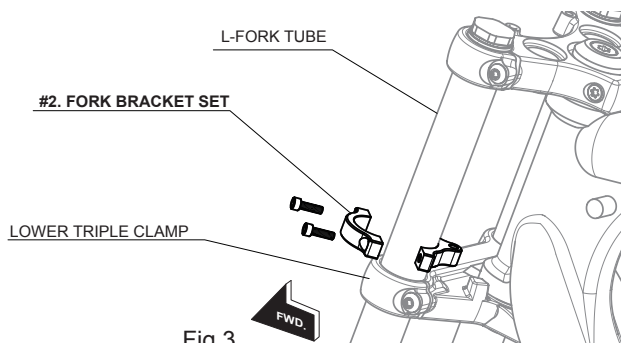

Fig.3

Install DAMPER BODY

3. Install the DAMPER BODY(#1) with the M8X25 BUTTON HEAD SCREW(#8).

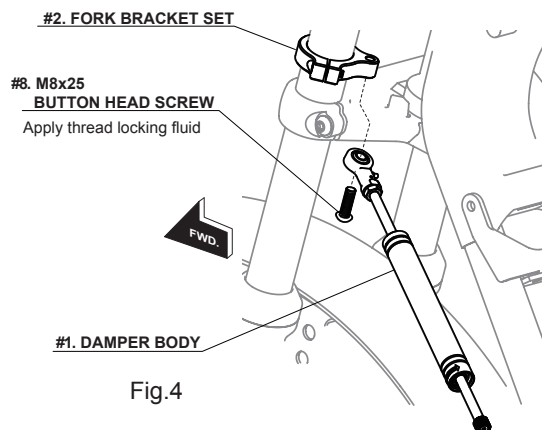

Fig.4

Position to fix FORK BRACKET

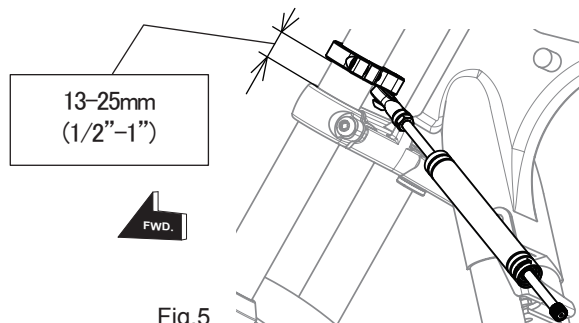

Fig.5

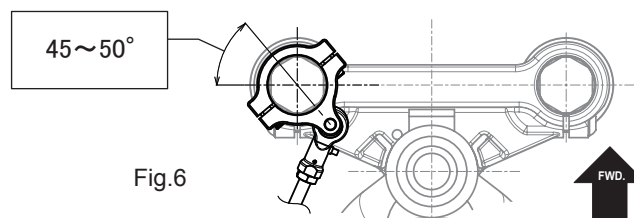

Fig.6

Install BODY CLAMP

DO NOT over tighten the damper body clamp. The stabilizer body can be damaged.

**Each motorcycle has different tolerance. Therefore, different combination of the fork bracket angle and the body clamp may be necessary within small range instead of indicated positions by the diagrams.

Adjust the bracket and the body clamp to the set stabilizer on the best position if necessary.

Turn the handlebar and check the steering to see if it reaches both right and left steering stoppers completely. Make sure the stabilizer does not hit or rub against the fork tube, frame, engine or the front brake line under the steering stem.

Tighten all bolts and nuts after to make sure the installation done right. Then adjust to your desired level of dampening.

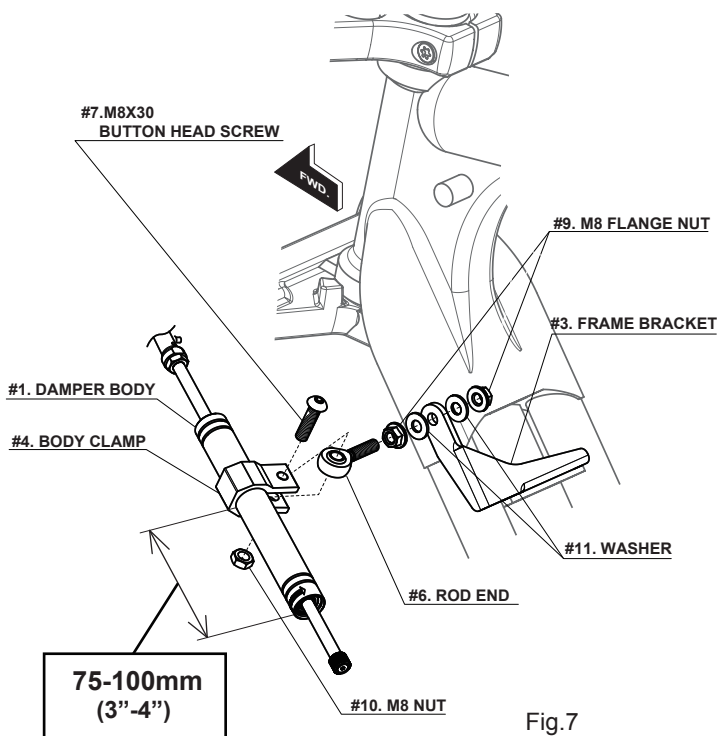

Fig.7

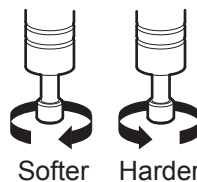
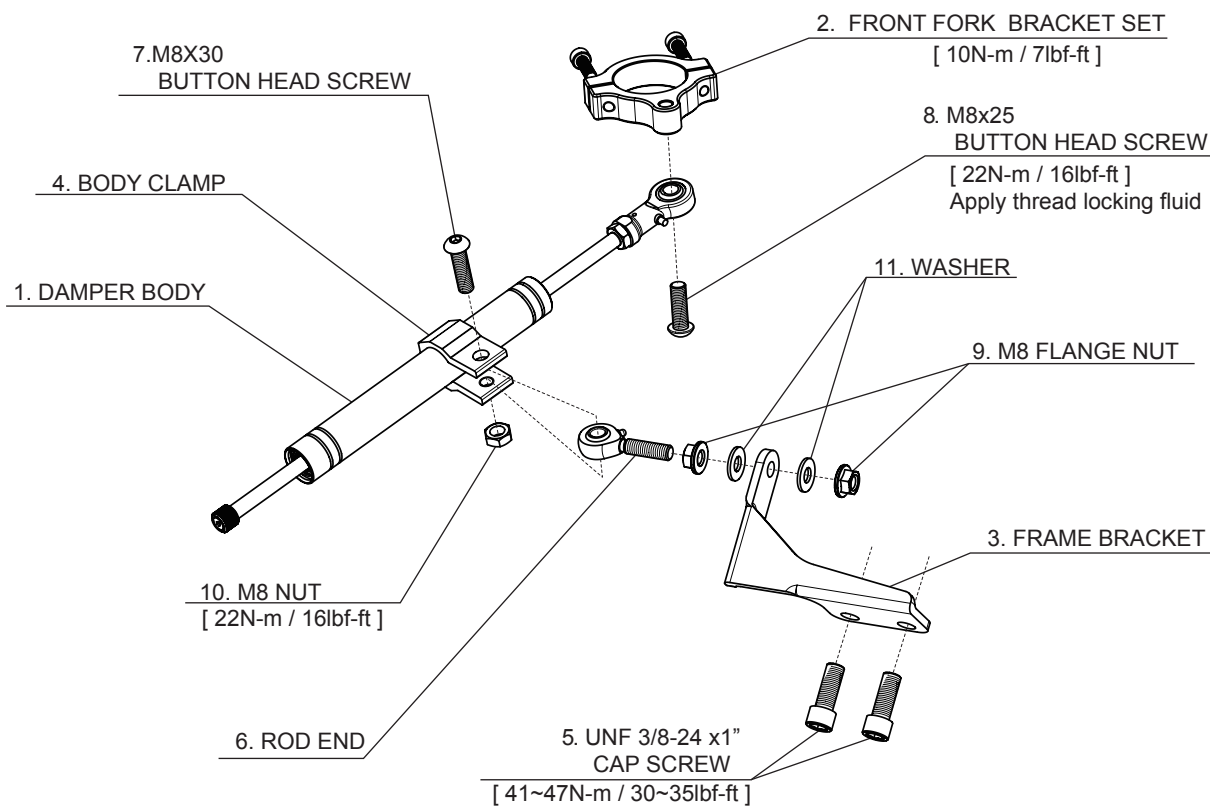

Fig.8

How to adjust the damping force

Turn the adjustable knob clockwise → Harder

Turn the adjustable knob counter-clockwise → Softer



DAYTONA

HIGH PERFORMANCE PARTS AND ACCESSORIES FOR ALL MOTORCYCLE LOVERS.

<http://www.daytona-global.com>