

MORE POWER : LESS NOISE



Congratulations, you have purchased the finest air intake system for your motorcycle on the market. Your Vance & Hines Air Intake system is designed and crafted for maximum performance and a perfect fit. Please follow the installation instructions below and if you have any questions, please call our technical support line at (562) 926-5291.

Attention installer (if other than owner), please forward this instruction sheet to the owner of this product. These instructions contain valuable information to end user.

This kit fits all 2000-later Softail, 1999-2007 Dyna, and Touring Twin Cam 88 and 96 model motorcycles (except 1999-2001 EFI Touring, 2006-2007 CVO FLHTCUSE/2 and 2008-later Touring models). Fits stock, big bore CV, and flatslide carburetors (except CV51 super bore).

TOOLS REQUIRED

- 3/8" Combination wrench
- 3/16" Allen wrench
- 5/32" Allen wrench
- T27 Torx wrench
- 1/4" or 3/8" drive Ratchet
- 3/8" Hex socket
- 7/16" Hex socket
- 5/16" Allen socket
- 5/32" Allen socket
- Inch-pound Torque wrench
- Loctite 243 (blue)

READ ALL INSTRUCTIONS BEFORE BEGINNING INSTALLATION

OEM SYSTEM REMOVAL

1. Take off the air filter cover by removing the 5/16"-18 x 1/2" OE button head cap screw in the center. Set the air filter cover and the screw aside for re-use.
2. This will expose the filter element, which is then removed by taking out the three Torx head cap screws.
3. Also remove the breather hoses from the cylinder head breather bolts by pulling on them.
4. Remove the three bolts that secure the backing plate to the carburetor / throttle body and the two breather bolts that secure it to the cylinder heads.
5. Now remove the backing plate and gasket, on FI models the wiring mount clip should be carefully pulled out of the plastic housing. NOTE: Be sure that the gasket surface is clean and dry and that no gasket material remains stuck to it.

INSTALLATION OF VOZ AIR FILTER KIT

1. For a clear understanding of this installation it is best to refer to the exploded view diagram while reading these instructions.
2. When installing or servicing the air cleaner, apply Loctite 243 (blue) to threads of all fasteners.
3. Loosely install the carburetor / throttle body mount bracket (1) and gasket (6) using the two cylinder head breather bolts (3) and breather bolt O-rings (2). NOTE: Make sure the gasket is installed with the correct rotation and right side up with the slightly smaller bleed hole in the top left hand corner. Tighten the cylinder head breather bolts (3) to 120-144 in-lbs (13.6-16.3 Nm) being careful not to pinch the breather bolt O-rings (2).
4. Install the breather hoses (4 & 5) through the top two holes in the filter backing plate (7), aligned as shown.
5. Using the three 1/4"-20 x 2-1/4" socket head cap screws (10) sandwich the filter mount bracket (9), the venturi (8) the filter backing plate w/ breather hoses (7) and install onto the throttle body. The slightly smaller bleed hole should be in the top left hand corner of the backing plate (7) and should line up with the bleed hole of the gasket (6), mounting bracket (1) and venturi (8). Make sure the inside edges of all of these parts are aligned before tightening to 55-60 in-lbs (6.2-6.8 Nm). NOTE: On fuel injected models a mount tab on the carburetor / throttle body mount bracket (1) is supplied to mount the stock wiring mount clip.

- Using the remaining three 1/4"-20 x 1/2" button head cap screws (12) install the air filter element (13) and torque to 55-60 in-lbs (6.2-6.8 Nm). NOTE: The Vance & Hines logo should be at approximately three o'clock when viewed from the side. The filter is pre-oiled and does not need to be oiled prior to installation.
- Feed the 5/16"-18 x 1/2" OE button head cap screw through the OE Air cover and into the center of the air filter element (12), tighten securely.
- After 100 miles check to be sure that these bolts are still tight. Periodically ensure that these screws remain tight.

VANCE & HINES OPTIONAL ACCESSORIES

FUELPAK



FUEL MANAGEMENT:

Take the guess work out of fuel injection with Fuelpak Fuel Management. Contact your local dealer or call (562) 921-0071 to order. Visit fuelpakfi.com for more information.

Fuelpak is intended for racing or off-highway use only, and is not legal for sale or use in California on pollution-controlled vehicles.

D100FL
71013
71015

Replacement Air Filter Element
Chrome Skullcap Cover
Black Skullcap Cover

MORE POWER : LESS NOISE

EXPLODED VIEW DIAGRAM

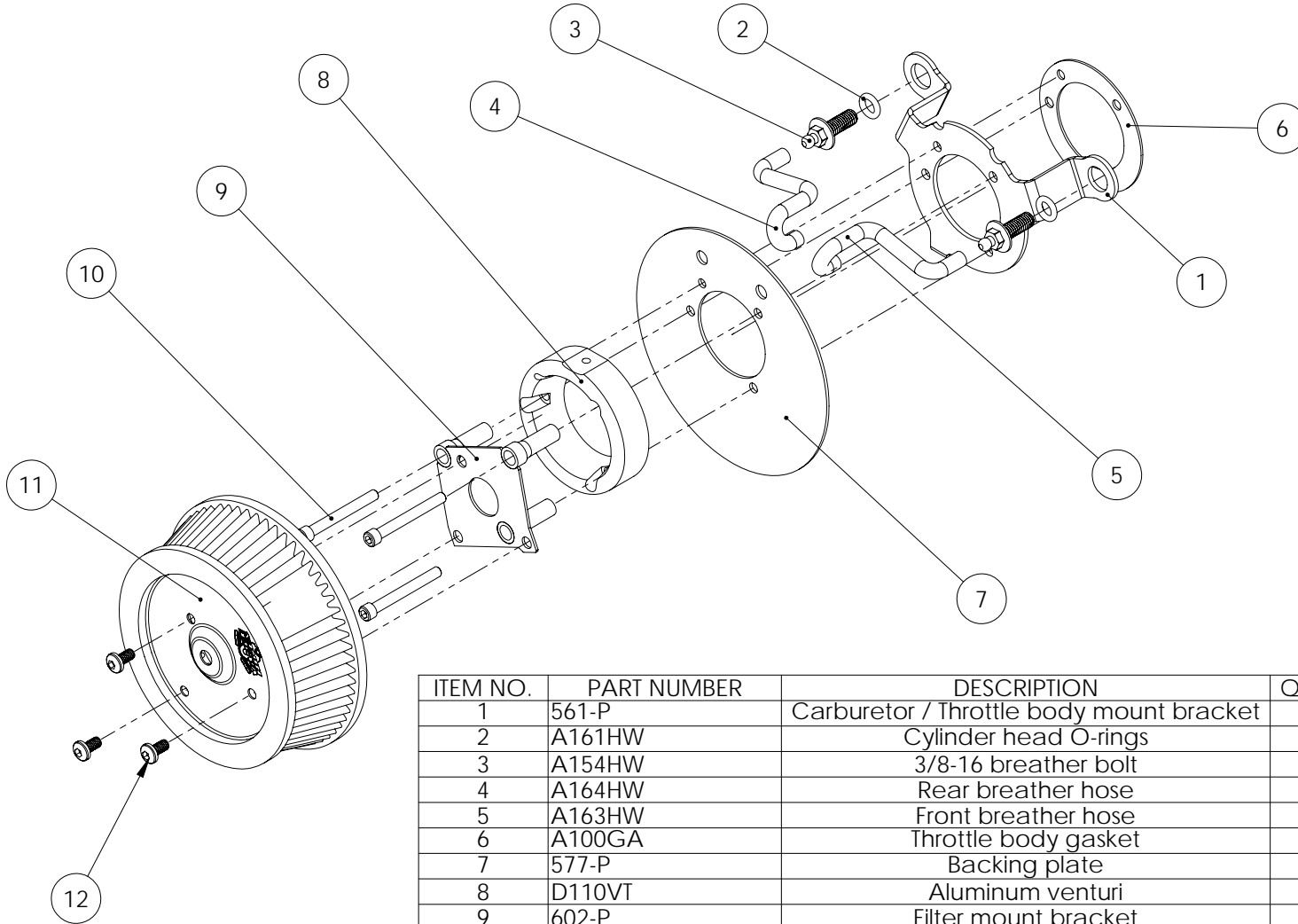

ITEM NO.	PART NUMBER	DESCRIPTION	QTY.
1	561-P	Carburetor / Throttle body mount bracket	1
2	A161HW	Cylinder head O-rings	2
3	A154HW	3/8-16 breather bolt	2
4	A164HW	Rear breather hose	1
5	A163HW	Front breather hose	1
6	A100GA	Throttle body gasket	1
7	577-P	Backing plate	1
8	D110VT	Aluminum venturi	1
9	602-P	Filter mount bracket	1
10	A152HW	1/4-20 x 2.25L Socket head cap screw	3
11	D100FL	Air filter element	1
12	A235HW	1/4"-20 x 1/2" Button head cap screw	3

WARRANTY

Vance & Hines products are warranted against defects in material and workmanship for a period of 90 days from the date of purchase from an authorized dealer. This warranty does not cover discoloration of chrome finishes. This warranty is limited to the repair or replacement of a product proven to be defective from normal use. Vance & Hines products are designed to fit and operate on OEM motor and chassis. This warranty does not cover any product subject to abuse, misuse, improper installation or modification.

FUEL MANAGEMENT

GET THE MOST OUT OF YOUR RIDING EXPERIENCE...

AN AFTERMARKET EXHAUST SYSTEM IS ONLY YOUR FIRST STEP, NOW YOU NEED FUEL MANAGEMENT.

NOW YOU NEED FUELPAK.

Your fuel injected Harley-Davidson® is equipped with an ECU (electronic control unit) that's programmed to deliver fuel to the motor based on an air/fuel ratio for a stock air filter and stock exhaust system. When you install a performance exhaust system, your airflow changes, so you need a fuel management system that adjusts your air/fuel ratio to match the changes. That fuel management system is Fuelpak. Fuelpak adds and takes away fuel, allowing for a more precise range of refinement in your air/fuel ratio. Get the perfect fuel management combination with your Vance & Hines exhaust system, get Fuelpak. For more information visit the tuning center at fuelpakfi.com

NOTICE: Fuelpak is intended for racing or off-highway use only, and is not legal for sale or use in California on pollution-controlled vehicles.



MORE POWER : LESS NOISE

13861 ROSECRANS AVENUE / SANTA FE SPRINGS, CA 90670
SALES: (562) 921-5388 / TECHNICAL: (562) 926-5291 / FAX: (562) 802-0110
VANCEANDHINES.COM