



## Instruction HD XL & XR license plate kit (208917-18)



### TOOL REQUIREMENT

Installation time: 120 min.

- Tools list :
- 1) Allen wrench metric set
  - 2) Torx wrench set
  - 3) Allen wrench Inch set
  - 4) 10 mm. spanner wrench
  - 5) 3/8 - 3/4 Inch spanner wrench
  - 6) Wire stripping pliers
  - 7) Medium threadlocker
  - 8) Wire stripping pliers
  - 9) Connector Crimp Tool
  - 10) Warmer gun
  - 11) Scissor lifter

**Free Spirits Genuine Parts to be fitted by trained technician only**



Tel. 0039 (0) 445-390437  
Fax 0039 (0) 445-395539

Email [info@freespirits.it](mailto:info@freespirits.it)  
Site: [www.freespirits.it](http://www.freespirits.it)

# ATTENTION!

Before starting the installation:  
Turn key to ON and remove the big GREEN fuse on battery side.

1



Check schemes from page. 7 to decide the number of wire that will be used. Insert wires into the bracket and leaving 20 cm. outside on license plate side as photos.

2



Secure two screw with thread lock as photos.

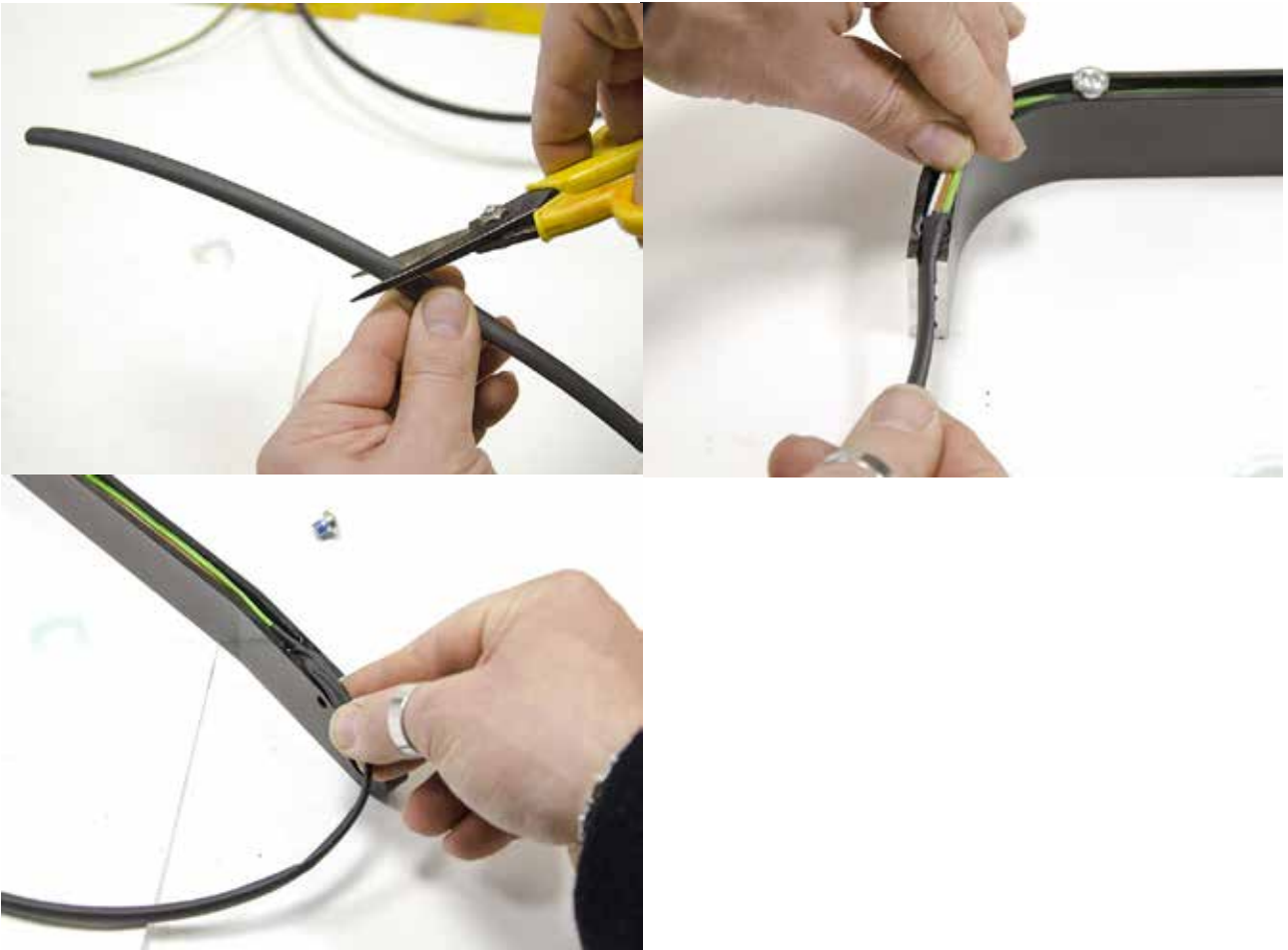

3

Cut a piece 200mm. the shrink tube (10mm type). and insert in the cables on license plate side as photos.  
Insert shrink tube remaining on the opposite side.



4

Secure two remaining screws as photos.



5



Screw and tighten with nut, the threaded pin supplied as photos.

6



Fasten license plate support as photo.

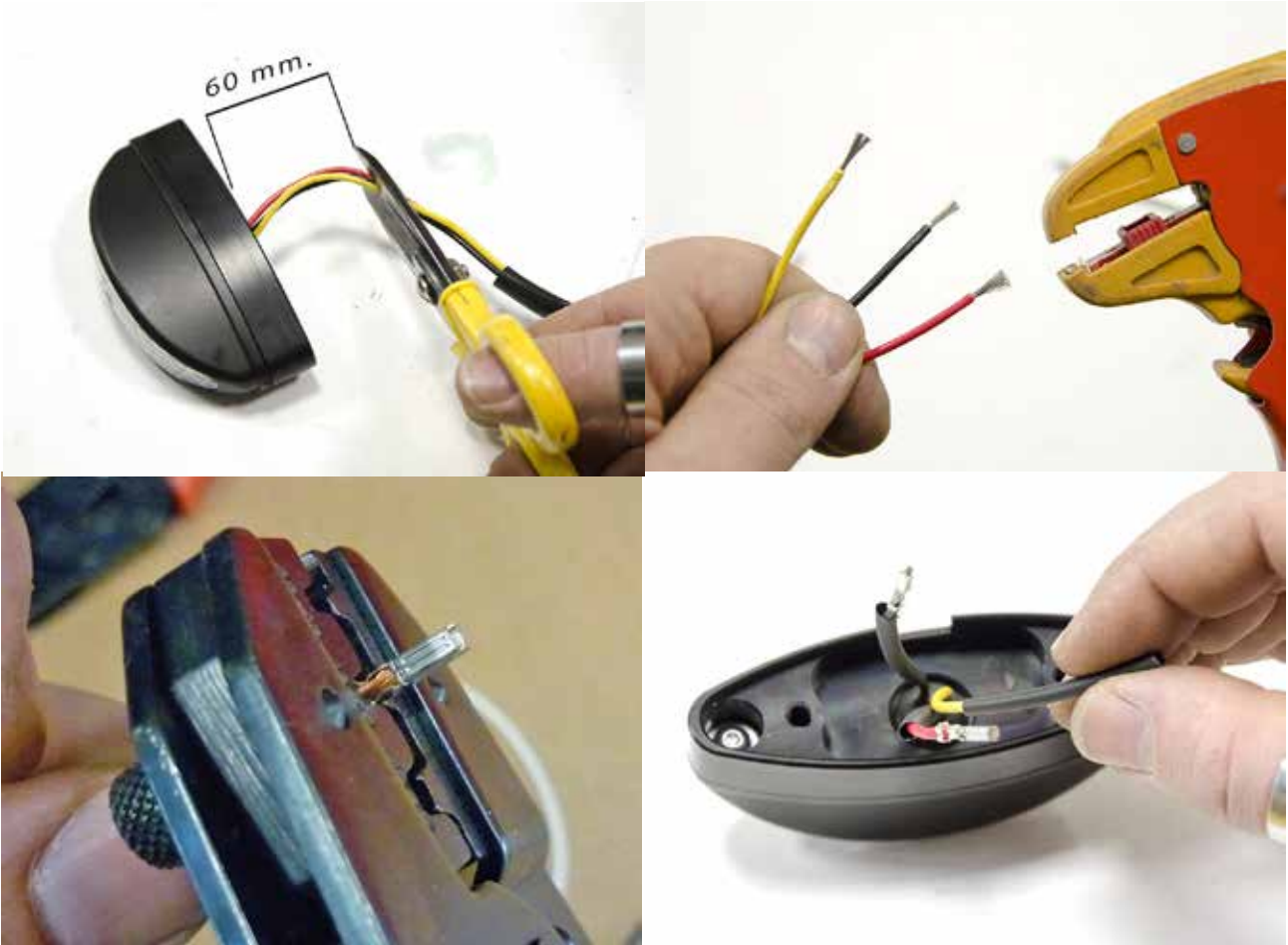

7

Shorten to 60 mm. the taillight wiring.  
Crimp female connectors as photo.

**Attention !. If you want weld connections with tinning, not use connectors.**

Cut small shrink tube in pieces of 50 mm. and insert as photos.



8

Crimp male connectors as photo.

**Attention !. If you want weld connections with tinning, not use connectors.**



9

Connect as photos and insulate.  
Insert wires on taillight support as photo.



10

Apply thread lock and secure as photo.

# ATTENTION !

The LED lights are tested by us one by one, checking the resistance to vibration and power surges, shall thereafter considered completely reliable in every feature.

To avoid disappointment, it is necessary to make a Correct wiring of lights, connecting the wires according to this scheme:

## TAIL LIGHT

YELLOW Cable = (GROUND) with : BLACK

BLACK Cable = (TAIL LIGHT) with : BLUE

RED Cable = (BRAKE LIGHT) with : RED/YELLOW

## Lh turn signal

BLACK Cable = (GROUND) with : BLACK

(OEM PURPLE) Cable = (+) with : PURPLE

## Rh turn signal

BLACK Cable = (GROUND) with : BLACK

(OEM BROWN) Cable = (+) with : BROWN

Free Spirits Srl. is not responsible for any injury or damage arising from not observance of the wiring diagram of the above.

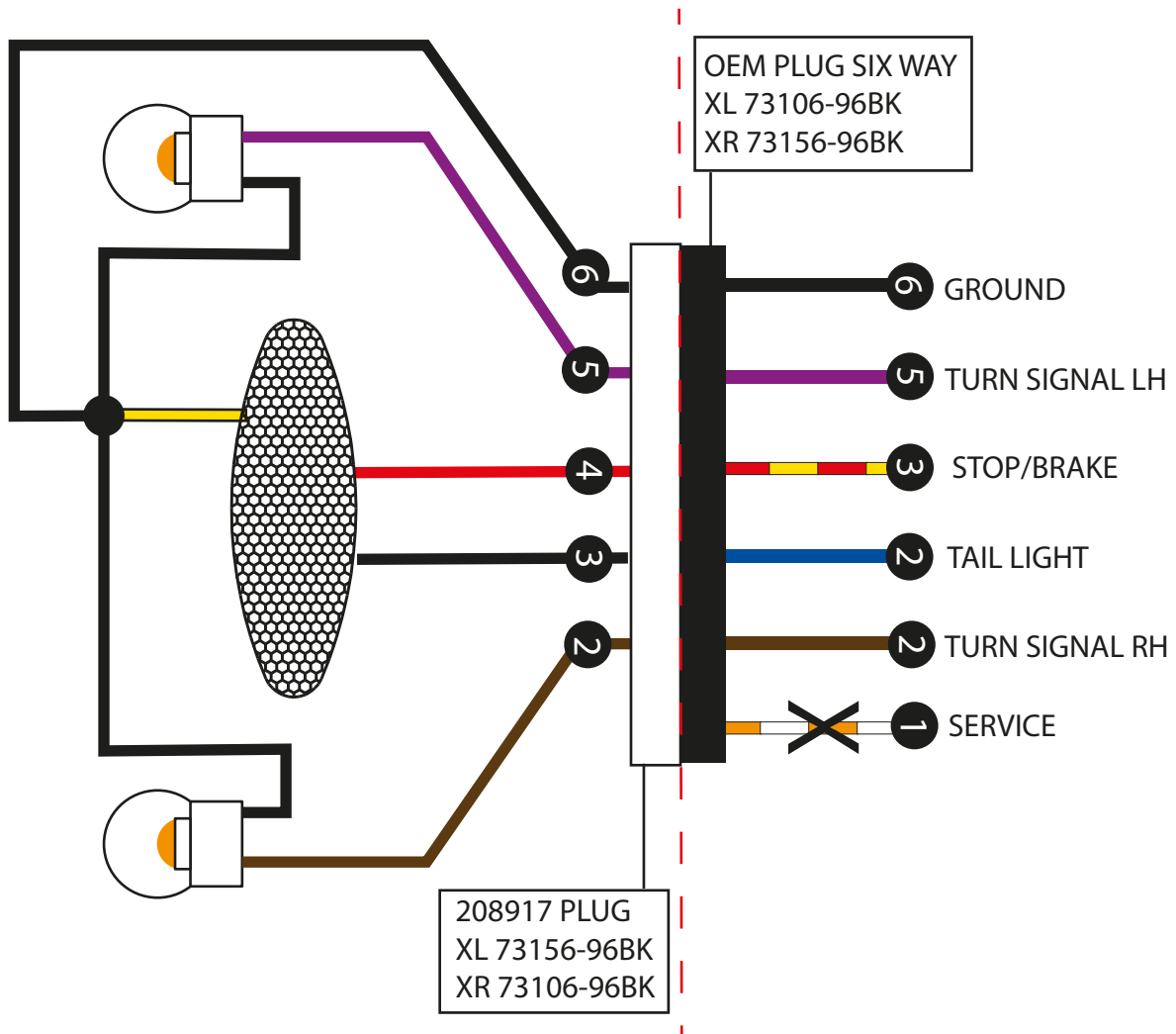



# ONLY FOR REAR TURN SIGNAL WITH TAIL LAMP & BRAKE LIGHT MODELS

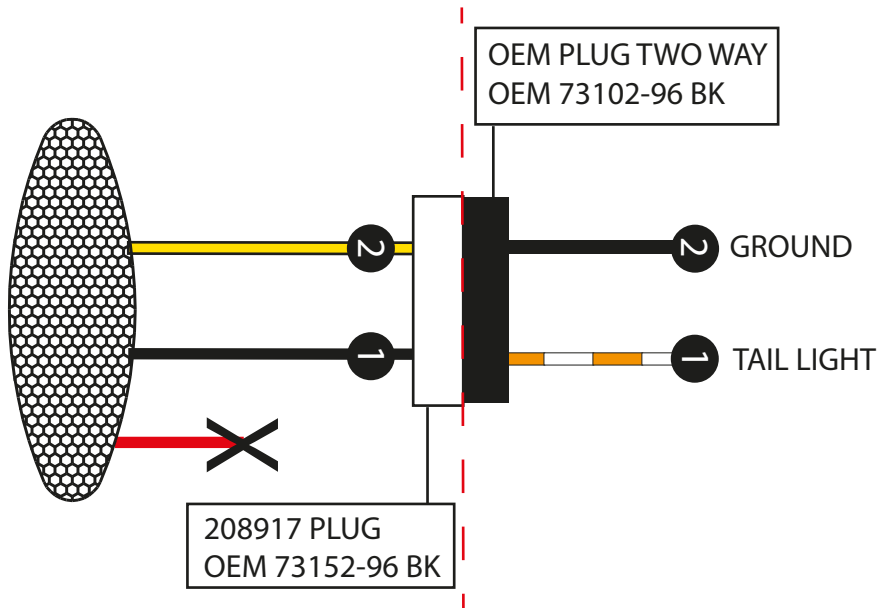

11

Remove seat, disconnect OEM tail light and remove license plate holder. Attention: for XR model will need to remove the tail. On XR model the plug is inside on tail light.





12

To support the bike, lift it under the frame.  
Remove shock absorber bolts LH.



13

Insert and secure 1/2 unc x 2-1/2" allen bolt as photo.  
On XR model requires a additional spacer.



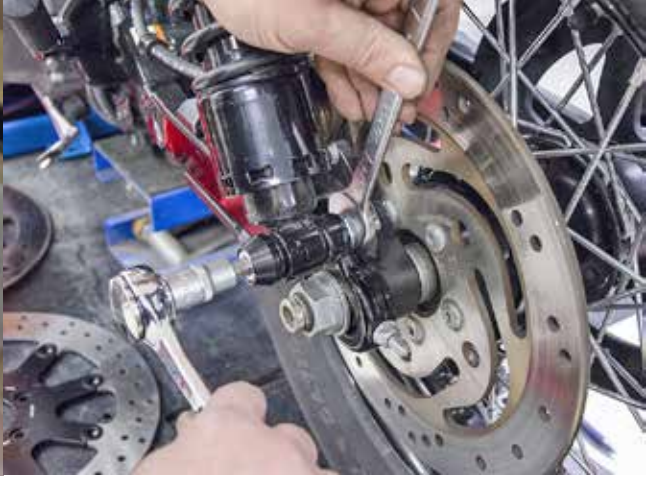

14

Insert and secure 1/2 unc x 3-1/2" allen bolt as photo.



15

Remove shock absorber RH.



16

Insert 1/2 unc x 3" Allen bolt + bushing + spacer on top head and secure.

## ATTENTION!

Insert a supplied (Grower washer) between the bracket and swingarm.



17

Insert 1/2 unc x 3-1/2" allen bolt as photo and place license plate.





18

Secure as photo.



19

Choose cable path.



20



Apply three clamp as photo and secure on swingarm.

ONLY FOR 2-WAY CONNECTOR (XL)



21

Bring cable into the top of frame, near the OEM plug.  
Attention: in this mode of installation, the brown cable (red - brake light) is not used.  
Crimp female connectors as photos.  
Insert connectors in 2-way plug and connect to OEM wiring.

## 6-WAY CONNECTOR (XL)



22

In case of use OEM turn signals, pull off contacts from original plug.  
Make ground cable as photos.  
Join ground cables with blue connector provided and connect the cable.



23

Crimp female connectors as photos  
Insert all connectors in 6-way plug (See on page 7)



24



Connect to OEM wiring.  
Attention: To avoid contact with the plate holder, the OEM mudguard must be replaced or cut.

### 6-WAY CONNECTOR (XR)



25

Make ground cable as photos.  
Join ground cables with blue connector provided and connect the cable.

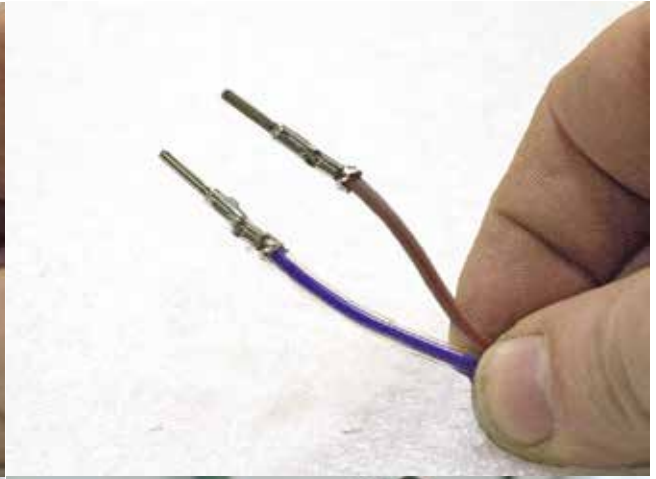
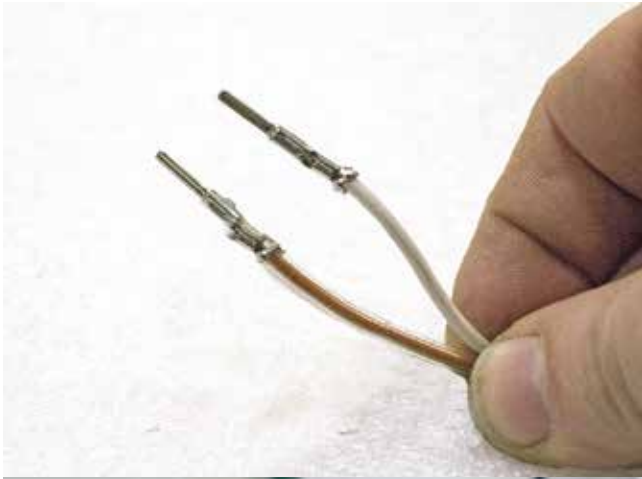

26

Crimp male connectors as photos  
Insert all connectors in 6-way plug (See on page 7)  
Connect to OEM wiring.



# XL Licence-holder code 208917

Wire Harness  
208917 C

MCS 941000

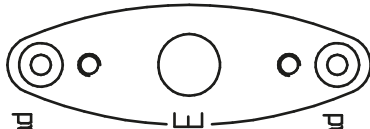
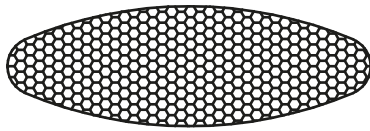

Bottomhead  
M6x16



208917 E



Bottomhead  
M6x16

Bottomhead  
M6x16



208917 B



Bottomhead  
M6x16

Bottomhead  
M6x16

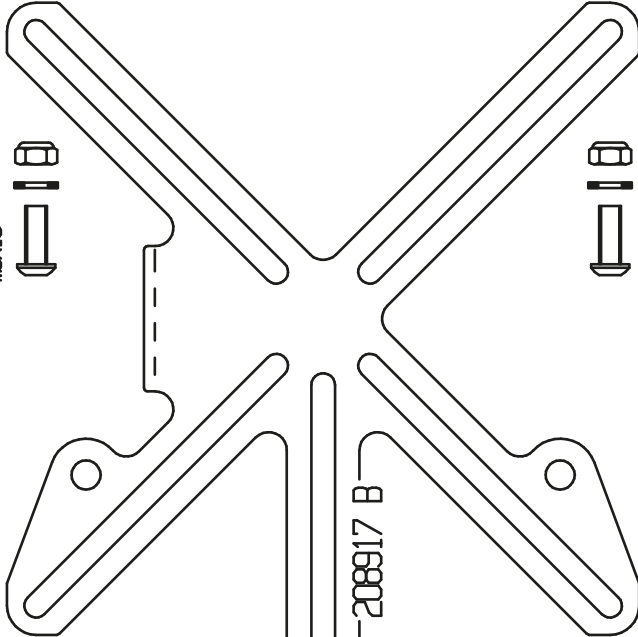

Bottomhead  
M6x16

208917 DB



All thread  
1/2 UNC x 2 1/2

208917 DA

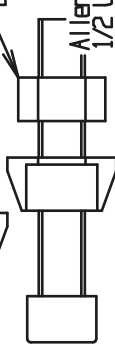

All thread  
1/2 UNC x 3"

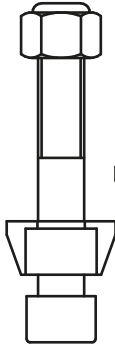

All thread  
1/2 UNC x 3"

208917 DC



All thread  
M6x16

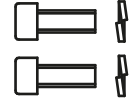

208917 A



headless  
M6x25

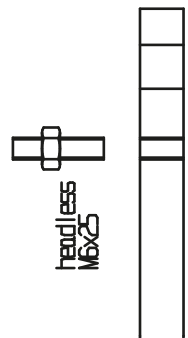

X  
Y

# XR-1200 Licence-holder code 208918

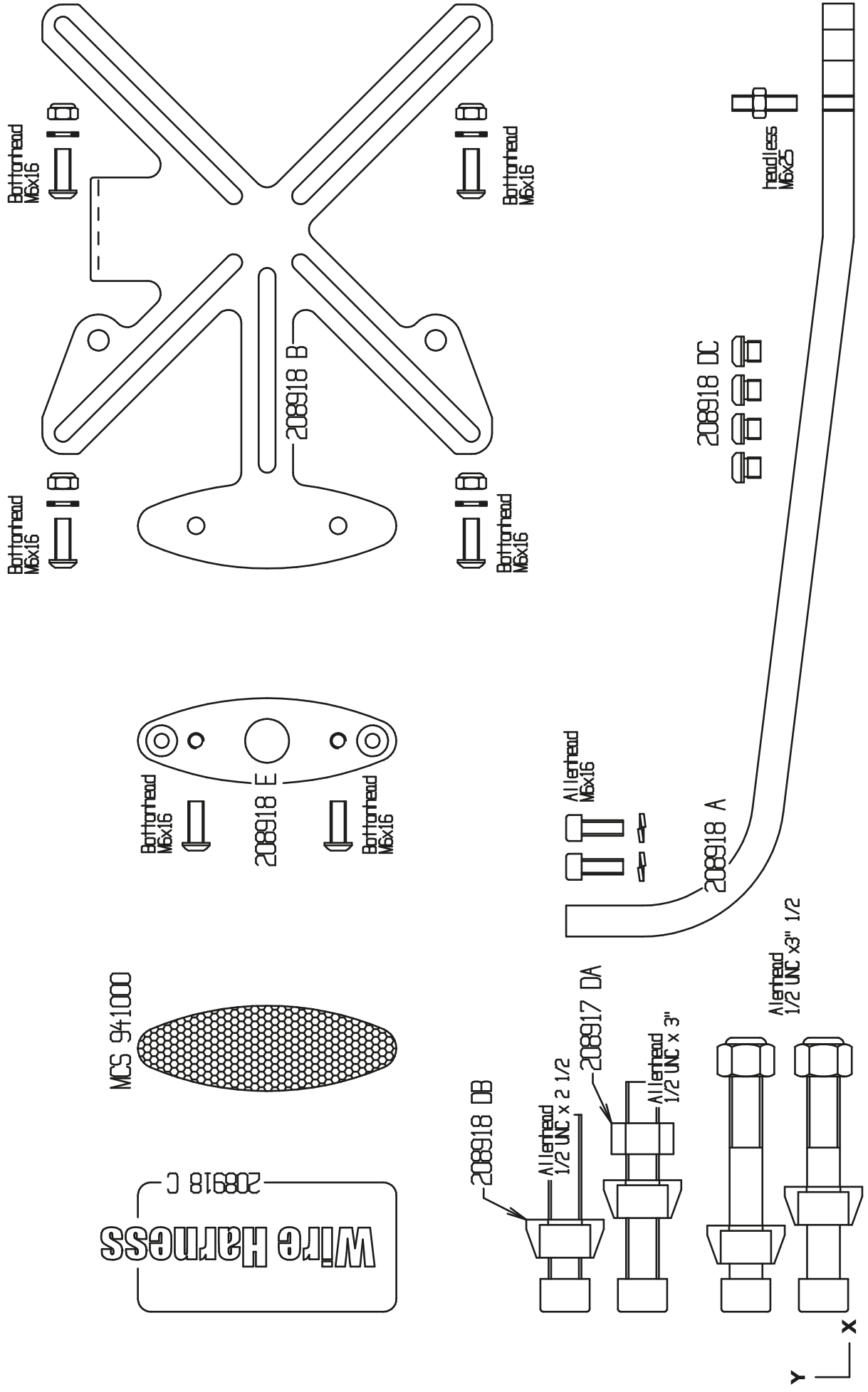





With the shipment of the order the buyer accepts the following conditions

#### **Warranty**

1. The SELLER warrants, for a period of twelve months after the date of delivery of the PRODUCTS to the BUYER, that the PRODUCTS are free from defects in manufacture and/or design which make the PRODUCTS unsuitable for the use for which the SELLER expressly represented to the BUYER the PRODUCTS are intended.

2. The SELLER shall be released from the guarantee in case the BUYER has misused, altered or modified the PRODUCTS without the consent of the SELLER, or has failed to communicate, via registered mail, the defects of the PRODUCTS or the lack of conformity thereof.

3. The SELLER shall be released from any responsibility if :

- a) the replacement and/or the repair of the PRODUCTS is to be accounted to force majeure events, as described under article 7 below, or the BUYER's, or its clients', fault or negligence; or
- b) the PRODUCTS, or parts thereof, have been misused or mishandled by the BUYER or its clients.

4. The SELLER shall be entitled to withdraw any defective PRODUCTS from the market, at its own expenses, and to obtain, to the extent it is possible, the BUYER's assistance in this respect

5. Such with the exception of fraud, the SELLER shall be responsible exclusively for repairing and/or replacing any PRODUCTS which are defective and/or not complying with the order. For this purpose is made prior obligation to the BUYER, on penalty of forfeiture to the warranty:

- a) To report in writing to the seller by registered letter with acknowledgment of receipt the presence of the reported flaws within eight days of delivery of PRODUCTS or within eight days of discovery of the defects themselves if hidden;
- b) To return at his own expense to the SELLER, warehouse , any defective products , in order to allow the verification of the presence of defects or inefficiency by the seller's quality control.

6. In no event shall the SELLER's liability of any kind include any damages to persons or property or any indirect, incidental or consequential losses which may have been caused to the BUYER or third parties by any defects or lack of conformity of the PRODUCTS

7. The SELLER sells the PRODUCTS only and exclusively to authorized workshops performing the PRODUCTS installation to ensure a good quality installation to the final consumer and any after-sales guarantees, the SELLER therefore does not entitle the PURCHASER to give for whatever reason the PRODUCTS to anyone without also providing installation. In case such an event occurs, the SELLER is relieved of any responsibility and the BUYER assumes any consequences related to lack of installation.

8. It is understood that the PURCHASER assumes all responsibility for problems that may arise due to the incorrect installation of the PRODUCTS.

#### **Claims**

-We check carefully and we pack accurately our goods before shipment. All claims due to damage or loss during the transport must be passed directly from the buyer to the courier that made delivery.

Consequently it is important that the buyer opposes terms on the relative bill of lading, so as he could receive possible reimbursements.

-Free Spirits srl company is not responsible for damages during transport.

#### **Final revisions**

-Free Spirits srl company has got no connection with Harley-Davidson, Buell and Triumph brands. They are used only as references.

-The BUYER declares to be completely informed that some PRODUCTS in this catalogue could not comply with the Italian Traffic Code or with the Traffic Code of other Countries. The buyer takes charge of any installation on motor-cycles which circulate on open traffic roads.

-Free Spirits srl company declines any responsibility with the wrong use of its accessories.

To read " Terms of Service" visit our website: <http://www.freespirits.it>



Telefono 0039 (0) 445-390437  
Fax 0039 (0) 445-395539

Email [info@freespirits.it](mailto:info@freespirits.it)  
Site: [www.freespirits.it](http://www.freespirits.it)