



**MORE POWER : LESS NOISE**



Congratulations, you have purchased the finest exhaust system for your motorcycle on the market. Your Vance & Hines exhaust system is designed and crafted for maximum performance, a perfect fit, a great sound and unbeatable style. Please follow the installation instructions below and if you have any questions, please call our technical support line at (562) 926-5291.

Attention installer (if other than owner), please forward this instruction sheet to the owner of this product. These instructions contain valuable information to the end user.

**TOOLS REQUIRED**

- Flat blade screwdriver
- 1/4" & 5/16" Nutdriver
- 1/2", 9/16" & 14mm Combination wrenches
- 1/4", 3/16" & 5/16" Allen wrench
- Snapping pliers
- Ft./Lb. Torque wrench
- 3/8" Ratchet & Extensions, 1/2" Socket, 1/2", 9/16" & 5/8" deep sockets,

**READ ALL INSTRUCTIONS BEFORE BEGINNING INSTALLATION**

**STOCK EXHAUST SYSTEM REMOVAL**

1. Remove both left and right saddlebags and set them aside. Remove right side panel.
2. Loosen the the pinch clamp bolt on the front end of muffler(s). NOTE: On OE two into one right side only exhaust systems, there is no left side removal of mufflers required
3. Remove the two 5/16" bolts and washers that mount the muffler(s) to the saddlebag supports. Save these for re-use.
4. Remove the stock mufflers and set them aside. NOTE: It may be necessary to use a penetrating lubricant to loosen the muffler from the head pipe.
5. Locate and unplug the O2 sensor wire connectors from the wiring harness (Grey and Black connectors behind right side panel) and remove cable ties holding wires to frame. Feed the end of the wires through the frame so they are free from the motorcycle. NOTE: Pay attention to wire routing for re-installation.
6. Remove the right hand floor board.
7. Remove the right hand passenger floor board.
8. Loosen head pipe clamp connecting the left side muffler to the header and the mount bracket on the backside of the oil pan. Remove the crossover section of head pipe and head pipe clamp (OE dual muffler systems only).
9. Remove the mount clamp located behind the oil pan, set the 1/4"-20 x 3/4" screws aside for reuse.
10. Loosen the nut and carriage bolt holding the head pipe assembly to the bracket on the transmission housing.
11. Loosen the heat shield clamps on both front and rear exhaust pipes.
12. Remove the two flange mounting nuts from each head pipe, located at the cylinder head. Carefully remove the head pipes and set them aside.
13. Using a 14mm wrench, carefully remove the O2 sensors from the stock head pipes and save for re-use with the new system.
14. Carefully remove the exhaust port flanges and circlips from the stock exhaust system using snapping pliers. NOTE: If circlips look bent or twisted, replace them.
15. Remove the stock exhaust gaskets and replace them with the V&H exhaust gaskets (supplied). V&H kit #22899 (see accessories) is available for future use.

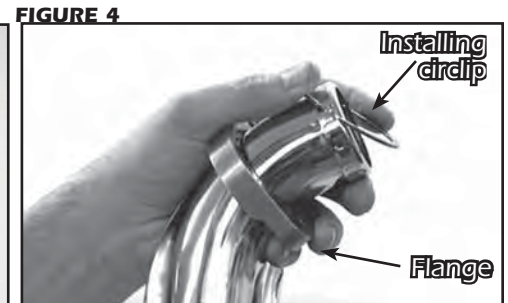
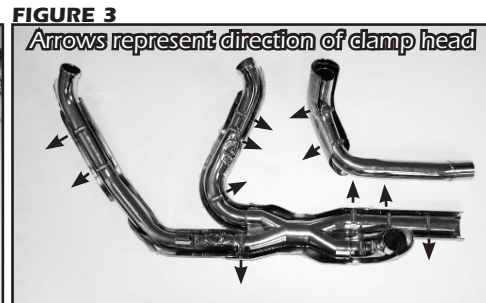
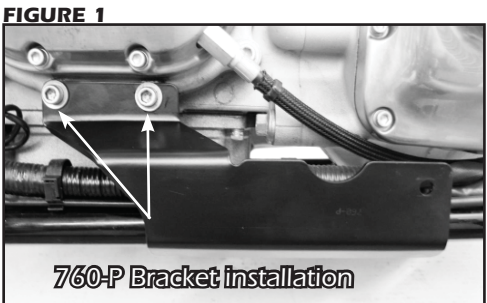

**FIGURE 5**

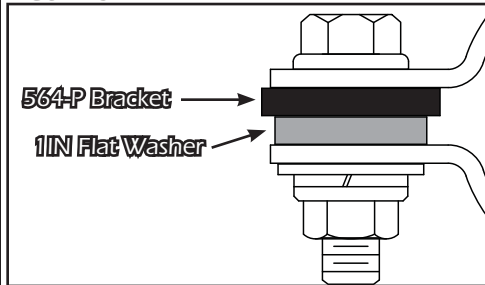

**FIGURE 6**



**FIGURE 7**



**FIGURE 8**

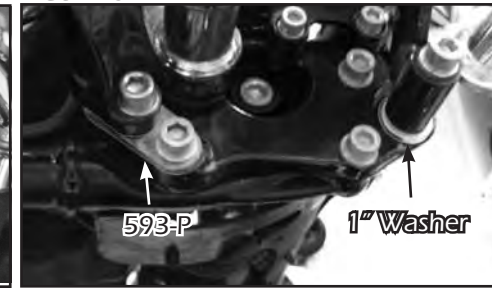

**VANCE & HINES EXHAUST SYSTEM INSTALLATION**

1. Install the crosspipe support bracket (stamped 564-P) at the stock mount clamp location behind the oil pan with the stock 1/4"-20 x 3/4" screws (Figure 6). NOTE: Do not fully tighten at this time.
2. Replace the bracket on the transmission housing with new bracket (stamped 760-P) (supplied) tighten enough to hold bracket in place but allow for adjustment later (Figure 1).
3. Remove header assembly and heat shields from protective packaging. Place each heat shield on a non-abrasive surface such as blanket or carpet. Using a felt tip pen, mark outside edge of each heat shield to show location of mounting clips that hose clamps will loop through (Figure 2).
4. The header assembly (D587FC) will require heat shields stamped D592HC, D593HC, D572HC, D573HC, D574HC. The remaining heat shield D557HC will be used on the crosspipe header (D558FC)
5. Lay header assembly into heat shields and loosely install the #20 hose clamps (supplied) into mounting clips (Figure 2). Screw heads should be accessible when the system is installed on motorcycle for adjustment purposes (Figure 3). Do not tighten at this time. NOTE: The D573HC heat shield should be installed with the scalloped end towards the collector.
6. Use the #28 hose clamps and install the collector heat shield (D574HC) over the other heat shields, it can be installed after header is installed if desired.
7. Apply a small amount of anti-seize compound to the threads of the O2 sensors and install them into the new header assembly (Grey connector into front headpipe, Black connector into rear headpipe). NOTE: Be careful not to get anti-seize on sensor tip, it may affect sensor function.
8. Install circlips and flanges from stock system onto the new header pipes (Figure 4).
9. Using stock flange nuts, carefully install the header assembly onto motorcycle. finger tight only at this time.
10. Use the nut plate and 5/16" x 5/8" flange bolt (supplied) to attach the header to the bracket. Make adjustments to the bracket as necessary to insure proper alignment.
11. Use 1/4" Allen wrench to tighten one or both transmission bolts to hold bracket alignment. Remove header and fully tighten transmission bolts to 13 - 16 ft/lb
12. Again, using stock flange nuts, carefully re-install the header assembly onto motorcycle. Do not tighten at this time.
13. Use the nut plate and 5/16" x 5/8" flange bolt (supplied) to attach the header to the bracket.
14. Tighten the exhaust port flange nuts and the 5/16" x 5/8" flange header bracket bolts.
15. Install the Torca Band Clamp (supplied), with nut facing down on the expanded end of the front head pipe (Figure 6).
16. Referring to Figure 5 - Fasten the crossover pipe to the crossover bracket using supplied hardware. First place the crossover bracket between the arms of the header clamp. Next insert the 3/8"-16 x 1.25 flange head bolt through the header clamp, crossover bracket, heavy 3/8" washer and once again the arm of the header clamp. Lastly install a 3/8" thin flat washer and 3/8"-16 lock nut. NOTE: Do not tighten at this time.
17. Attach crossover header (D558FC) loosely to heat shield (D557HC) and slip into end of front head pipe.
18. Tighten the stock 1/4"-20 screws securing the bracket to the oil pan, rotate crossover head pipe (D558FC) to proper position for muffler being used and tighten flange head bolt and locknut securing the crosspipe clamp (A223CC) to the rear transmission bracket.
19. Install the mufflers of your choice onto both head pipes and secure to saddlebag supports with the stock 5/16" bolts and lock washers. On bike equipped with OE 2 into 1 systems, Vance and Hines Left Side Mount kit #16933 may be required to complete installation
20. Check alignment of mufflers and make corrections as required.
21. Tighten the band clamps securing the crosspipe and the mufflers to the head pipes.
22. Be sure to check that all fasteners including the hose clamps on the heat shields are tight.
23. Route the front (Grey) O2 sensor wire along OE path and plug into the Grey connector. Route the rear (Black) O2 sensor along the top of the transmission along the OE path and plug into the Black connector. Secure wires to the frame using supplied nylon cable ties. Remove one right rear nut securing transmission top cover. Re-install it with the supplied wire fastener capturing the rear O2 wire, securing the wire away from exhaust pipes. (Figure 7).
24. Install Spacer (593-P), on floor board support plate (Figure 8). Remove the left 3/8" socket cap screw only and place the spacer onto floor board support plate aligning the holes in the spacer with those on the support plate. Re-install the 3/8" socket cap screw into the original hole capturing spacer. NOTE: You may use the 3/8" stock socket cap screw to temporarily hold spacer alignment while tightening the 3/8" socket cap screw.
25. Install a 3/8" lock washer (supplied) on the 3/8"-16 x 3" socket cap screw (supplied). Using this bolt re-install the floor board with one 1" spacing washer (supplied) (Figure 8) on the forward (right) mount. NOTE: Spacing washer are located between the floor board supports and floor board mount plate. On 2010-11 CVO Models, a 3/8"-16 x1-1/2" socket cap screw (not supplied) should be used from the inside on the right mount rather than the 3/8"-16 x 3" provided bolt.
26. Re-install the right side passenger floorboard, saddlebags and right side panel.
27. Be sure to tighten all hardware before starting your motorcycle.
28. After installation and before starting the motorcycle, completely clean pipes and mufflers with cleaning solvent and a clean soft cloth that will not leave residue. NOTE: Any residue, oil, or fingerprints will stain the chrome when the metal heats up.

**EXHAUST CARE - HELPFUL HINTS TO AVOID DISCOLORATION OF EXHAUST SYSTEM**

1. When installing a new set of chrome pipes, make sure your hands are clean and free of oil. After installation, thoroughly clean pipes with a soft cloth and cleaning solvent that will leave no residue before starting the motorcycle.
2. Avoid long periods of idling as this can cause discoloration.
3. Intake leaks can cause the engine to run lean and overheat, this could lead to discoloration.
4. Make sure there are no exhaust leaks at the junction of the exhaust pipes and cylinder head. We recommend replacing gaskets if they are worn.

**VANCE & HINES OPTIONAL ACCESSORIES**

**FUELPAK**



**FUEL MANAGEMENT:**

Take the guess work out of fuel injection with Fuelpak Fuel Management. Contact your local dealer or call (562) 921-0071 to order. Visit fuelpakfi.com for more information. Fuelpak is intended for racing or off-highway use only, and is not legal for sale or use in California on pollution-controlled vehicles.

PLEASE NOTE: Every effort is made for Vance & Hines Exhaust Systems to provide improved cornering clearance. However, due to design and space limitations on some motorcycle models, ground and cornering clearance may not be improved and in some cases may be reduced. Be sure to follow proper installation instructions.



**PACKING LIST**

**MORE POWER : LESS NOISE**

**ALL PARTS SHOWN ARE ACTUAL SIZE**

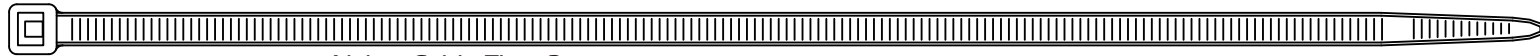

Nylon Cable Tie x 2

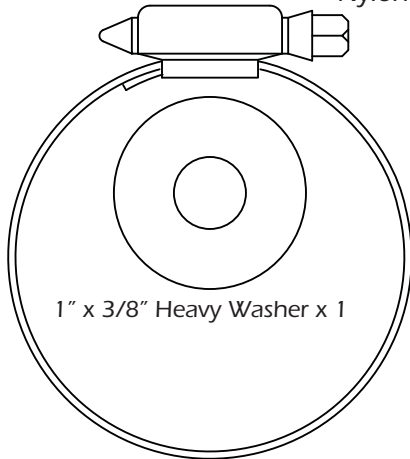

1" x 3/8" Heavy Washer x 1

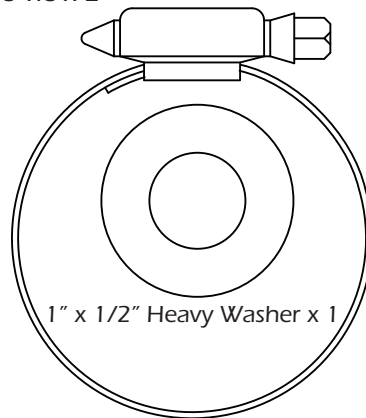

1" x 1/2" Heavy Washer x 1

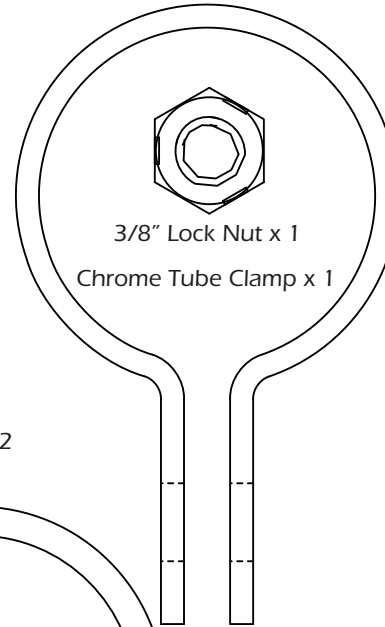

3/8" Lock Nut x 1  
Chrome Tube Clamp x 1

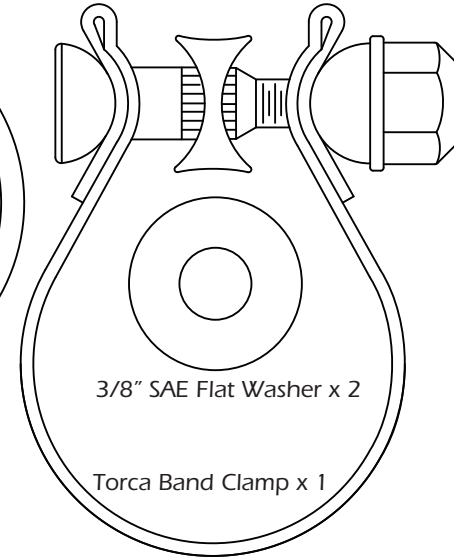

3/8" SAE Flat Washer x 2

Torca Band Clamp x 1

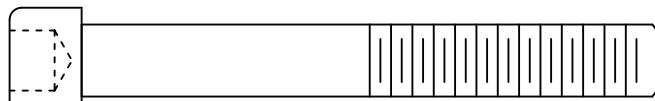

3/8"-16 x 3.0" Socket Head Capscrew x 1

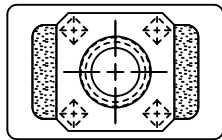

Single hole nut plate x 1

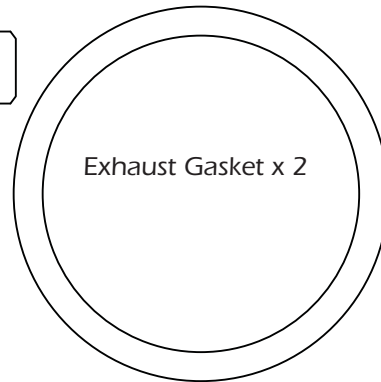

Exhaust Gasket x 2

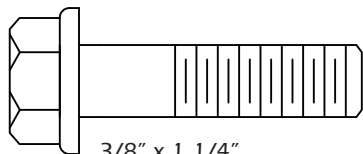

3/8" x 1 1/4"  
Flange Head Bolt x 1

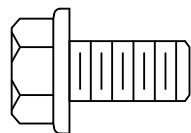

5/16" x 5/8"  
Flange Head Bolt x 1

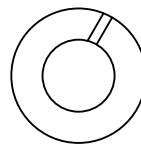

3/8" Lock  
Washer x 1

**PARTS NOT SHOWN:**

564-P	Mounting Bracket	x1
593-P	Spacer	x1
760-P	Mounting Bracket	x1
D587FC	Header Assembly	x1
D592HC	Front Heatshield	x1
D593HC	Rear Heatshield	x1
D572HC	90° Heatshield	x1
D573HC	Straight Heatshield	x1
D574HC	Collector Heatshield	x1
D558FC	Crosspipe Header Assembly	x1
D557HC	Crosspipe Heatshield	x1
A393HW	Loop Clamp	x1

**WARRANTY**

Vance & Hines exhaust systems are warranted against defects in material and workmanship for a period of 90 days from the date of purchase from an authorized dealer. This warranty does not cover discoloration of chrome finishes. This warranty is limited to the repair or replacement of a product proven to be defective from normal use. Vance & Hines exhaust systems are designed to fit and operate on OEM motor and chassis. This warranty does not cover any product subject to abuse, misuse, improper installation or modification.



## FUEL MANAGEMENT

### GET THE MOST OUT OF YOUR RIDING EXPERIENCE...

AN AFTERMARKET EXHAUST SYSTEM IS ONLY YOUR FIRST STEP, NOW YOU NEED FUEL MANAGEMENT.

### NOW YOU NEED FUELPAK.

Your fuel injected Harley-Davidson® is equipped with an ECU (electronic control unit) that's programmed to deliver fuel to the motor based on an air/fuel ratio for a stock air filter and stock exhaust system. When you install a performance exhaust system, your airflow changes, so you need a fuel management system that adjusts your air/fuel ratio to match the changes. That fuel management system is Fuelpak. Fuelpak adds and takes away fuel, allowing for a more precise range of refinement in your air/fuel ratio. Get the perfect fuel management combination with your Vance & Hines exhaust system, get Fuelpak. For more information visit the tuning center at [fuelpakfi.com](http://fuelpakfi.com)

NOTICE: Fuelpak is intended for racing or off-highway use only, and is not legal for sale or use in California on pollution-controlled vehicles.



MORE POWER : LESS NOISE

13861 ROSECRANS AVENUE / SANTA FE SPRINGS, CA 90670  
SALES: (562) 921-5388 / TECHNICAL: (562) 926-5291 / FAX: (562) 802-0110  
VANCEANDHINES.COM